

产品规格承认书
SPECIFICATION

文件编号 File No.: UME-EG-SP16092302/A1

客户 Customer	AKON	核准 Approval	ZL
品名 Product	开关电源 Switching power supply	品管确认 QC	LTF
型号 Model	AD-C120P400	审核 Check	ZL
日期 Date	2024-05-14	拟制 Execution	BMD

客户承认意见 Confirmation by Customer	客户签署 Stamp & Signature
<input type="checkbox"/> 合格 Accept	
<input type="checkbox"/> 不合格 Reject	
<input type="checkbox"/> 条件合格 Conditional Acceptance	

确认签署后，请回传一份。有任何问题，请尽快告知我们。

Please return one copy to us with your signature and feel free to contact us for any questions.

厦门友盟电子有限公司

XIAMEN UME ELECTRONICS CO., LTD.

电话 Tel:0592-2611448

地址：厦门市翔安区莲亭路火炬八方工业园10号楼882-7号8楼

Add: 8th Floor, No. 882-7, Lianting Road, Xiamen Torch Hi-Tech Zone (Xiang'an) Industrial Zone

产品规格承认书 SPECIFICATION				文件编号 File No.	UME-EG-SP16092301/A1
品名 Product	开关电源 SPS	型号 Model	AD-C120P400	日期 Date	2024-5-14

目录 INDEX

1	变更履历 Revision History.....	1-3
2	概述 Summary	2-4
3	技术要求 Technical requirements.....	3-4
	3.1安全标准 Safety Standards	3-4
	3.2Input.....	3-4
	3.3Output	3-4
	3.3可靠性及质量控制 Reliability and Quality Control	3-5
	3.4测试线路图 Test Circuit	3-9
4	线路图 Schematic Diagram	4-9
5	电路板图 P.C.B.....	5-10
6	CORD 图 (单位 unit: mm 颜色 color: Black)	6-11
7	AC CORD 图 (单位 unit: mm 颜色 color: Black)	7-12
8	外观示意图 Cord and Mechanical Drawing (单位 unit: mm 颜色 color: Black)	8-13
9	铭板标识 Label.....	9-14
10	包装方式 Packaging	10-14
11	材料清单 BOM.....	11-15

*** The products limited warranty period is 18 months.
(From date code of product.)**

● The products meet RoHS requirements.

批准 Approval:	ZL	审核 Check:	ZL	制表 Execution:	BMD
--------------	----	-----------	----	---------------	-----

产品规格承认书 SPECIFICATION				文件编号 File No.	UME-EG-SP16092301/A1
品名 Product	开关电源 SPS	型号 Model	AD-C120P400	日期 Date	2024-5-14

2 概述 Summary

2.1 本文件包含一般的客户要求及电气、机构和安全性能等方面的描述。

This document contains general customer requirements and those of specific electrical, mechanical and safety for this product.

3 技术要求 Technical requirements

3.1 安全标准 Safety Standards

Japan: 电安法别表第八【JET6108-61010-1009】

3.2 Input

Rated Input Voltage	100-240Vac
Operating Range	90-264Vac
Rated Input Frequency	50~60Hz
Rated Input Current	1.2A
Maximum Input Power	55W
Input Power (No Load)	0.1W Max
Primary Current Protection	Current fuse
AC Blade	<PS>E 2*0.75mm ² VFF Black, L:1800mm Lead-free soldering

3.3 Output

Rated output voltage	12V ± 5%
Rated Load Current	4000mA
Over Current Protection	4.0A Min @Vin=100Vac/240Vac
Line Regulation	The line regulation is less than ±2% while measuring at rated load and +/-5% of input voltage changing.
Ripple	≅ 200mVp-p
Switching Efficiency	87.8% minimum @ input 115AC/230VAC to meet DOE6
DC Plug	Φ2.1*5.5*9.5(EIAJ)
DC Cord	18AWG UL2464 L = 1500mm, Black Lead-free soldering

批准 Approval:	ZL	审核 Check:	ZL	制表 Execution:	BMD
--------------	----	-----------	----	---------------	-----

产品规格承认书 SPECIFICATION				文件编号 File No.	UME-EG-SP16092301/A1
品名 Product	开关电源 SPS	型号 Model	AD-C120P400	日期 Date	2024-5-14

3.3 可靠性及质量控制 Reliability and Quality Control

【Electrical Test Items】

Item	Conditions	Criteria
1	Leakage Current Measure the leakage current between Primary and Secondary when adding rated input. AC input = Rating voltage (100/240V)	Less than 250 μ A
2	ESD Test 1. Test is conducted at room temperature/humidity.(25°C, RH 50-60%) 2. Test set is 150pF/150 Ω . 3.(1) \pm 4KV:Contact discharge test. +phase: 3times, -phase: 3times, total: 6times. (2) \pm 8KV:Air discharge test. +phase : 3times, -phase: 3times, total: 6times. (Note) After each ESD test, it should be discharged.	No malfunction (must be in spec after test).
	1. Test is conducted at room temperature/humidity.(25°C, RH 50-60%) 2. Test set is 150pF/150 Ω . 3.(1) \pm 6KV:Contact discharge test. + phase: 3times, -phase: 3times total: 6times. (2) \pm 10KV:Air discharge test. + phase: 3times, -phase: 3times, total: 6times. (Note)After each ESD test, it should be discharged.	No destruction
	ESD Test (Ability test) 1. Test is conducted at room temperature/humidity.(25°C, RH 50-60%) 2. Test condition: 150pF/150 Ω . 3,Contact discharge / Air discharge 4,Load: 1)no load 2)rated load 5. Impressing 10 times continuously to plus and minus each. 6,Discharging once after impressing 10 times (To confirm the capacity of unit up to the unit destroyed)	It confirms at which voltage value the adapter breaks.(Note: Not part of qualification)
3	Hi-POT test Condition=AC3000V, 1min. Test place=Between AC blade and DC plug Sensitivity current=10mA	No malfunction. (damage, arc, breakdown etc)
4	Insulation resistance DC500V, 1min. Between AC blade and DC plug	More than 100M Ω
5	Temperature Rise Test 1. Apply rating input voltage(100/240V), 2. Load: Charge actual Cellular phone 3. Measure the surface temperature of the adaptor 4. T ambient = The room temperature 5. Condition: Until it carries out temperature saturation (the definition of temperature than 1°C in 1 hour). 1. Apply rating input voltage(100/240V),	Housing surface Temperature rise is less than 45K.
		Housing surface Temperature rise is less than 15K.

批准 Approval:	ZL	审核 Check:	ZL	制表 Execution:	BMD
--------------	----	-----------	----	---------------	-----

产品规格承认书 SPECIFICATION				文件编号 File No.	UME-EG-SP16092301/A1
品名 Product	开关电源 SPS	型号 Model	AD-C120P400	日期 Date	2024-5-14

		2.No Load 3.Measure the surface temperature of the adaptor	
6	Input over / under	Apply voltage=(rating input voltage)x(1±30%) Impressed time : 24h	No destruction
7	EMI/Conducted Emission	Telephone stand by mode with rapid-charge condition	Conform to: FCC 47CFR Part 15 Class B J55014-1
8	Surge	IEC61000-4-5 1.2×50µs 1.0KV Positive and negative all three times, Current limiting impedance 100 Ω, Time interval 30 seconds min.	No destruction.

【Environmental Test Items】

Item	Conditions	Criteria
1	Temperature range Electrical performance guarantees temperature range: 0°C to 40°C Electrical performance not guarantees working temperature range: -20°C to 50°C Storage temperature range: -30°C to 80°C	No abnormal appearance, mechanic performance or electric performance
2	High Temperature Leave 1. Temperature 80°C for 96 hours. 2. After that test, test set is left in normal temperature, humidity condition for more than 1hour, then evaluate.	No abnormal appearance, mechanic performance or electric performance
3	Low Temperature Leave 1. Temperature -30°C for 96 hours. 2. After that test, test set is left in normal temperature, humidity condition more than 1(hour), then evaluate.	
4	High Temperature Humidity 1. Temperature 50°C, air moisture 90-95% RH for 96 hours. 2. After that test, test set is left in normal temperature, humidity condition more than 30min, then evaluate.	
5	Temperature Humidity test 1. Temperature 40°C, air moisture 90-95% RH for 96 hours. 2. After that test, test set is left in normal temperature, humidity condition more than 30min, then evaluate.	
6	Heat Shock Test 1. Condition: -30°C/ 1 hour to +80°C/ 1 hour, 60 cycles 2. After that test, test set is left in normal temperature, humidity condition more than 1 hour, then evaluate.	
7	Heat/humidity Cycle Test A, C, D : RH=90±10% B : RH= 90±5% E : No limit After 5cycles, put EUT at room temperature/humidity condition	

批准 Approval:	ZL	审核 Check:	ZL	制表 Execution:	BMD
--------------	----	-----------	----	---------------	-----

产品规格承认书 SPECIFICATION				文件编号 File No.	UME-EG-SP16092301/A1
品名 Product	开关电源 SPS	型号 Model	AD-C120P400	日期 Date	2024-5-14

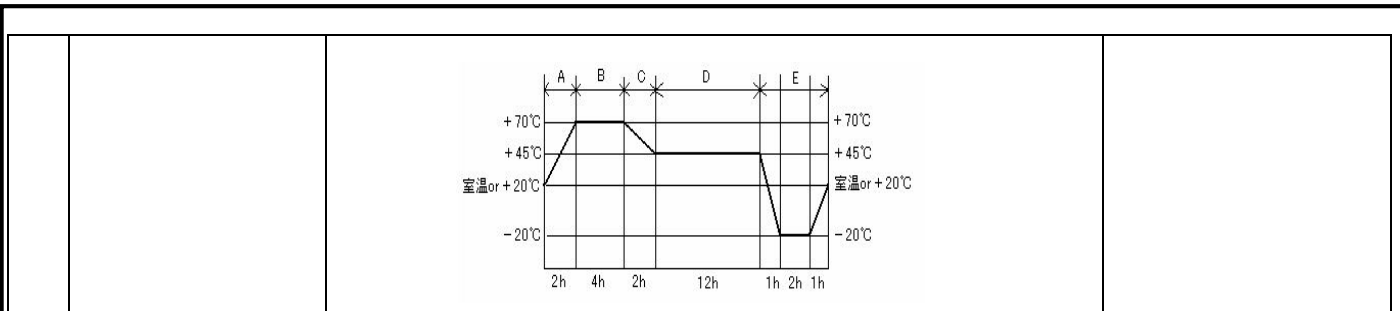

【Mechanical Test Items】

Item	Conditions	Criteria
1	Drop Test	No parts remove, no abnormal mechanic performance, (outside scratches are acceptable)
2	Package Drop Test	
3	Unit Vibration Test	
4	Package Vibration	
5	AC Plug in/out Test (AC Blade part)	
6	Exfoliate with cellophane tape and examine it	A character do not disappear. Don't take the label off the main body
7	The reliability to face each other to come off the label	
8	No tally part step	less than 0.25mm after an environmental examination

批准 Approval:	ZL	审核 Check:	ZL	制表 Execution:	BMD
--------------	----	-----------	----	---------------	-----

产品规格承认书 SPECIFICATION				文件编号 File No.	UME-EG-SP16092301/A1
品名 Product	开关电源 SPS	型号 Model	AD-C120P400	日期 Date	2024-5-14

【DC cord Test Items】

Item		Conditions	Criteria
1	DC Cord strength (adaptor side / plug side)	1. Test part: Between adaptor and DC cord 2. Pull a cord with 98N(10Kgf) force 3. Time: 1min.	No abnormality such as wire cut, bushing come off
2	DC Cord Bending Test (adaptor side / plug side)	Weight = 4.9N(500g) Angle = +/-90° Cycles in every minute = 40times/min. Test cycles = 1000times Note: contrarotate 90°, and then rotate it clockwise with 180°(+90° ~-90°) , and at last return to origin. (1 Cycle : 0° ⇒-90°⇒0°⇒+90°⇒0°)	Operate properly.

【Safety Test Items】

1	MTBF	Make a measurement condition, a calculation standard clear	More than 50,000 hours
2	Part materials	It is maintenance or the incombustibility of contact / part materials approaching it in an outer fence, the charge department of the electric part	same as UL94V-0; more than it
3	print board	Incombustibility	same as UL94V-0; more than it
4	No tally part step	Difference of the pitch by height differences of the tally part between casts	less than 0.25mm after an environmental examination

批准 Approval:	ZL	审核 Check:	ZL	制表 Execution:	BMD
--------------	----	-----------	----	---------------	-----

产品规格承认书 SPECIFICATION				文件编号 File No.	UME-EG-SP16092301/A1
品名 Product	开关电源 SPS	型号 Model	AD-C120P400	日期 Date	2024-5-14

3.4 测试线路图 Test Circuit

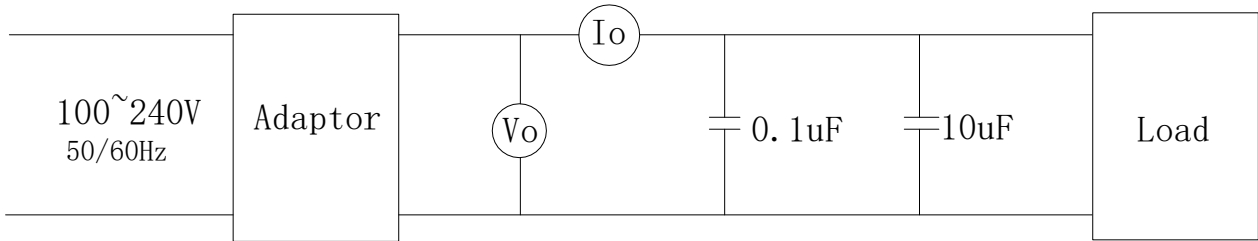

4 线路图 Schematic Diagram

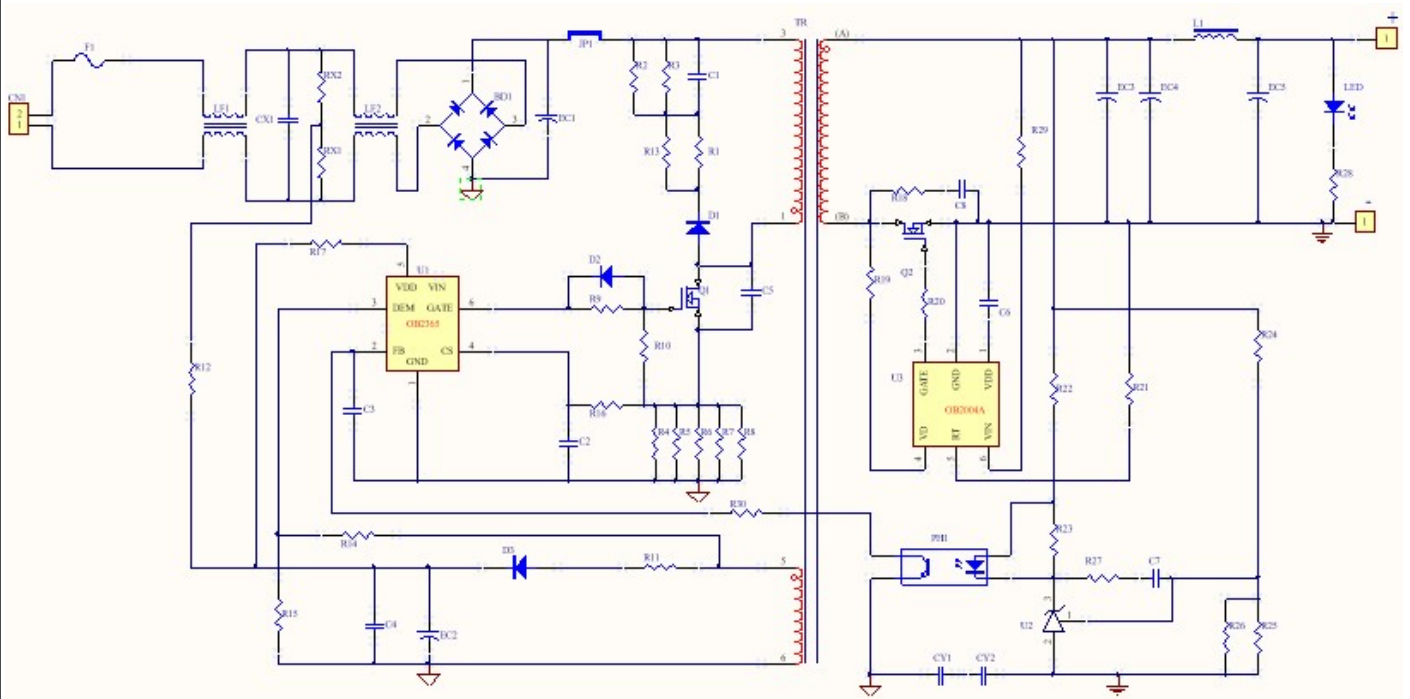

批准 Approval:	ZL	审核 Check:	ZL	制表 Execution:	BMD
--------------	----	-----------	----	---------------	-----

产品规格承认书 SPECIFICATION				文件编号 File No.	UME-EG-SP16092301/A1
品名 Product	开关电源 SPS	型号 Model	AD-C120P400	日期 Date	2024-5-14

5 电路板图 P.C.B

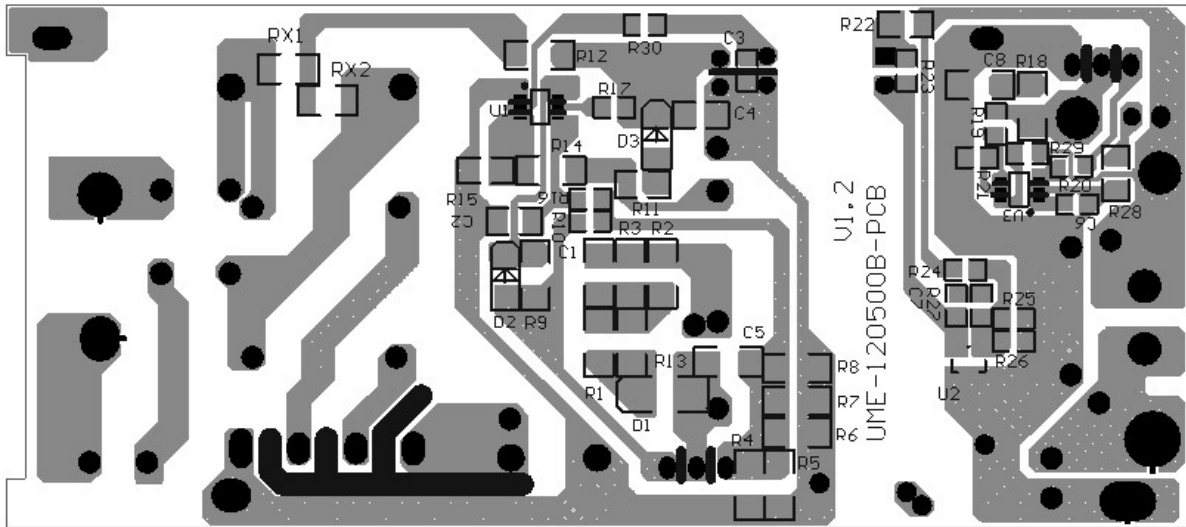
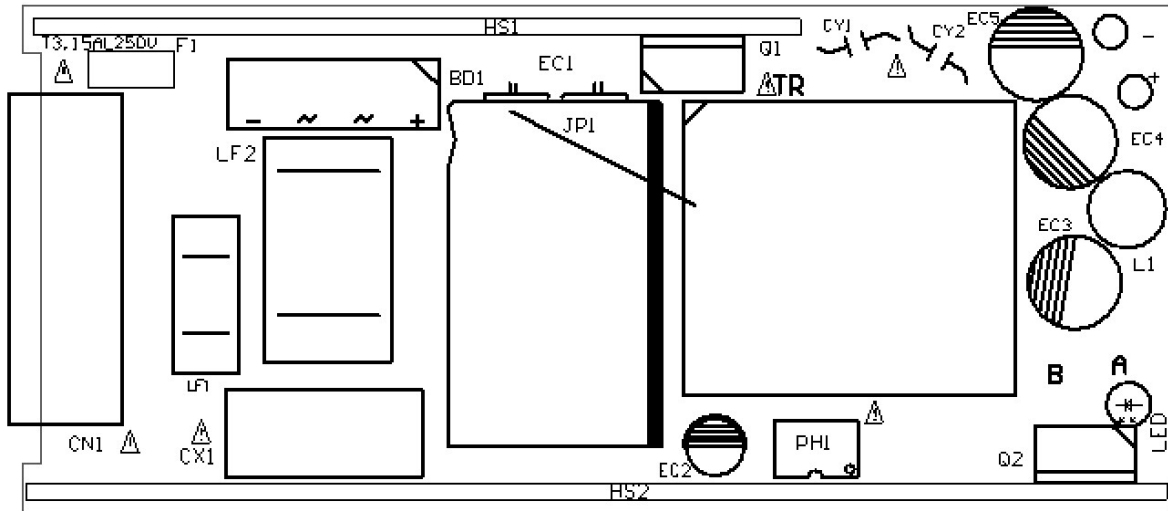

批准 Approval:	ZL	审核 Check:	ZL	制表 Execution:	BMD
--------------	----	-----------	----	---------------	-----

产品规格承认书 SPECIFICATION				文件编号 File No.	UME-EG-SP16092301/A1
品名 Product	开关电源 SPS	型号 Model	AD-C120P400	日期 Date	2024-5-14

6 CORD 图 (单位 unit: mm 颜色 color: Black)

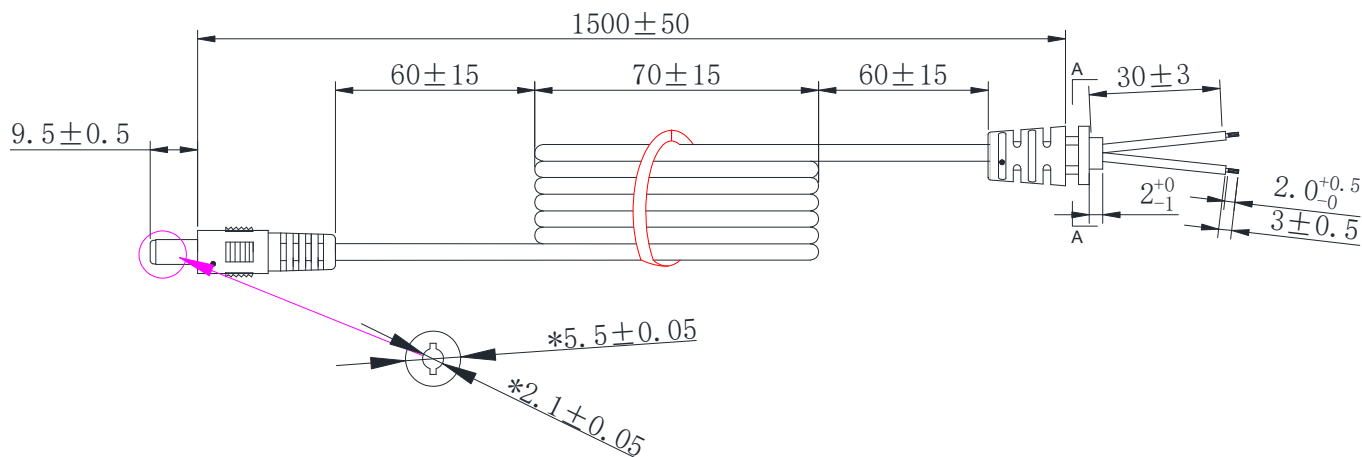

备注:

- 导线规格: 18AWG 2464 音叉型 黑色, 芯线颜色: 红色+黑色, 导线总长 1500mm; 材质符合RoHS要求。导线按图示尺寸捆扎、测试, 导线间应开路, 对应线头线尾应短路导通, 极性连接正确;
- 两头剥线焊锡, 剥线长度 $3\text{mm}+1/-0$ 。剥线要求如图所示, 剥丝线焊锡的直径为 1.5mm MAX 。接线方式: 红色芯线接PIN中心, 黑色芯线接外侧, PG头成型, SR-002成型; SR002尺寸为 $6.8*7.8\text{mm}$ 。
- SR拉力测试: 吊重 $1\text{Kg}/10$ 分钟, 不可有位移, 吊重 $5\text{Kg}/1$ 分钟, 位移 2mm MAX
- 插拔力测试: 插入力 2Kg f MAX , 拔出力 0.3Kg f MIN ; 插拔 6000MIN 次不允许有电气和机械性能的损坏, 且满足拔出力 0.1Kg MIN ;
- 摇摆测试: 吊重 500g , 以 40 次/分作 90° 往返, 每一往返为一次, 至少 1000 次;
- PLUG绝缘阻抗测试: $100\text{M}\Omega \text{ MIN}$ 在 $500\text{DC}/\text{分}$; PLUG接触阻抗测试: $100\text{m}\Omega \text{ MAX}$;
- 导线, SR, PLUG非移行性依据厂内一般进行; 禁止使用VDE所禁用的物质。
- 打*号尺寸, 为入料检查项目;

批准 Approval:	ZL	审核 Check:	ZL	制表 Execution:	BMD
--------------	----	-----------	----	---------------	-----

产品规格承认书 SPECIFICATION				文件编号 File No.	UME-EG-SP16092301/A1
品名 Product	开关电源 SPS	型号 Model	AD-C120P400	日期 Date	2024-5-14

7 AC CORD 图

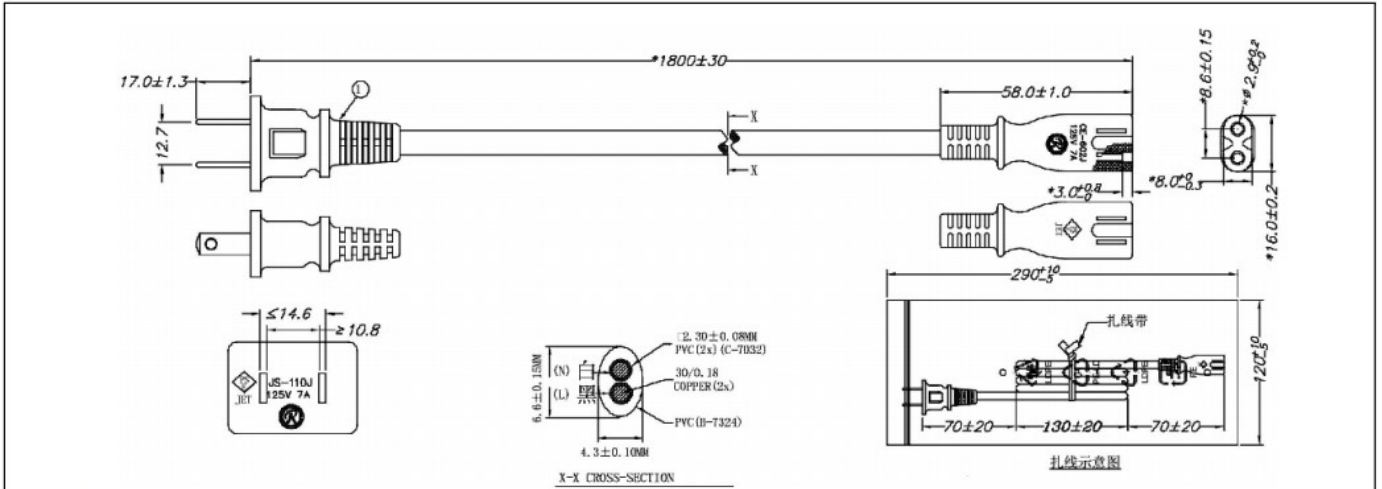

备注:

- 1、线材规格: VCTFK 0.75/2C BLK L:1800mm
- 2、导线按图示尺寸捆扎、测试。导线间应开路, 对应线头线尾应短路导通。
- 3、摇摆测试: 吊重500g, 以40次/分作60°往返, 每一往返为一次, 至少2000次。
- 4、插头、线及接口符合PSE (日本)标准。
- 5、材质符合“RoHS”要求。
- 6、测试参数: 内高压3KV, 时间1S, 外高压4KV, 时间为2S, 绝缘 5MΩmin, 时间1S 漏电流0.5mA。
- 7、头部: JS-110J 尾部: CE-602J
- 8、插拔力: 10N-50N
- 9、印字内容: R31945 RoHS <PS>E JET VCTFK 2*0.75mm² (30/0.18mm) 300V
 FUND RESOURCES ELECTRIC INDUSTRY CO., LTD SHANGHANG YEAR

厦 门 友 盟 电 子 有 限 公 司

版次	变更内容	制图	审核	批准	单位	mm	图 称	输入电源线	
		白美端			比例	2021-9-25	图 号	CORD-120500M	版本
			日期	产品型号	LJDY0120017		1.0		
				SW-120500T9					

批准 Approval:	ZL	审核 Check:	ZL	制表 Execution:	BMD
--------------	----	-----------	----	---------------	-----

产品规格承认书 SPECIFICATION				文件编号 File No.	UME-EG-SP16092301/A1
品名 Product	开关电源 SPS	型号 Model	AD-C120P400	日期 Date	2024-5-14

8 外观示意图 Cord and Mechanical Drawing (单位 unit: mm 颜色 color: Black)

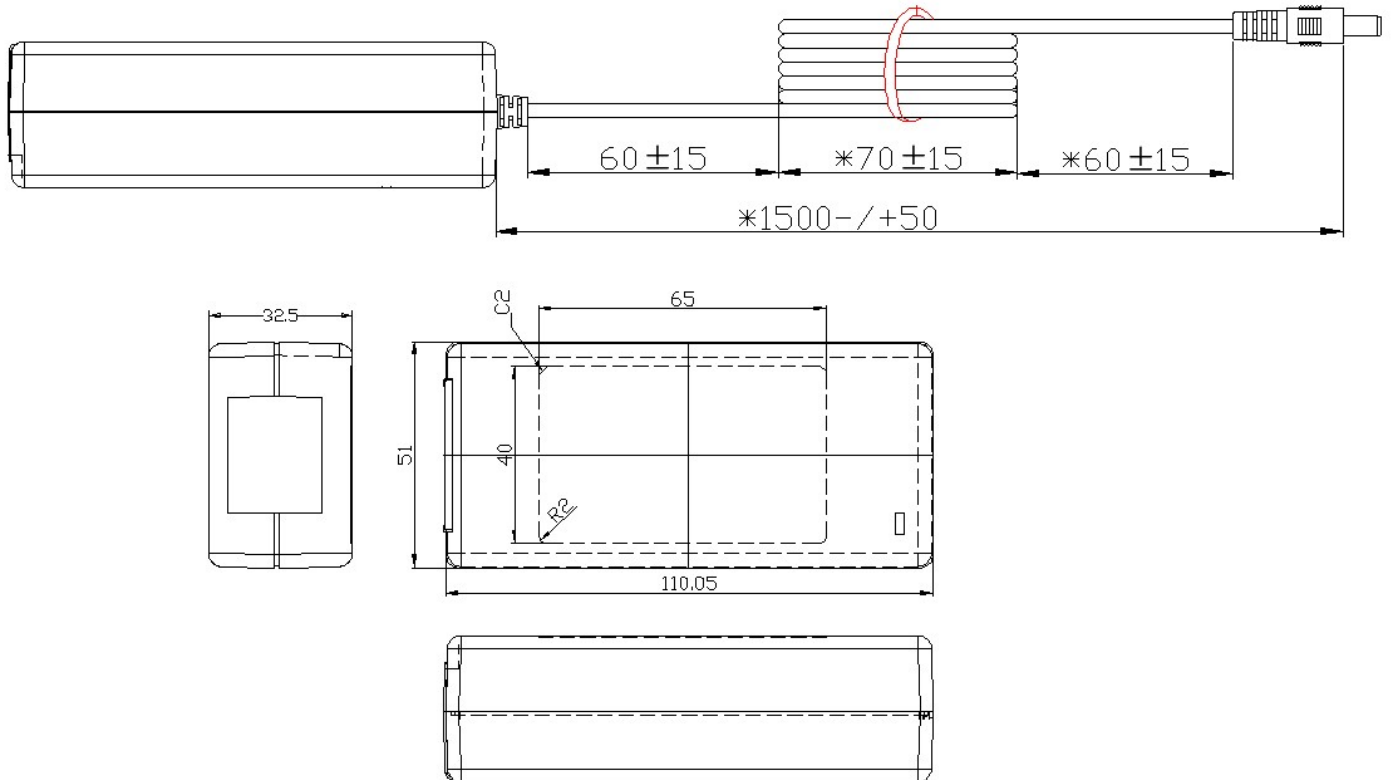

批准 Approval:	ZL	审核 Check:	ZL	制表 Execution:	BMD
--------------	----	-----------	----	---------------	-----

产品规格承认书 SPECIFICATION				文件编号 File No.	UME-EG-SP16092301/A1
品名 Product	开关电源 SPS	型号 Model	AD-C120P400	日期 Date	2024-5-14

9 铭板标识 Label

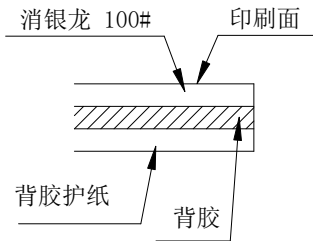

备注:

1. 材质: 消银龙 100# (铭板基材厚度0.1mm, 材质PET)。
2. 黑底银字, 亚膜, 印刷参照ARTWORK, 印刷位置居中。
3. 背胶: 高冠DT#。
4. 密着性: 将铭板贴于实际CASE上, 在-40° C下放置48小时, 再放入75° C, 90%RH下放置48小时后, 于常温常湿下放1小时, 在铭板长度方向上贴上强力胶带(3M NO.610 18mm宽或等价物), 以垂直方向急速拉起, 铭板不能有起泡或脱落。
5. 粘着力: 依据铭板检验标准测试。
6. YY表示年份, WW表示周期, 年周依订单要求或实际生产日而定。
7. 字体清晰可读, 布局居中, 字体或图案与铭板边缘距离大于0.4mm。
8. 铭板字体为方正姚体。

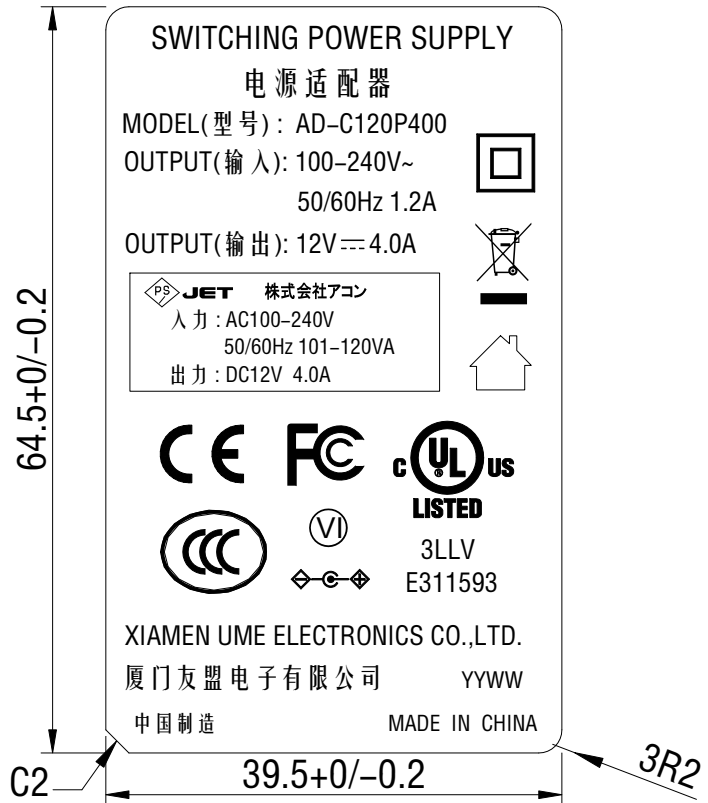

10 包装方式 Packaging

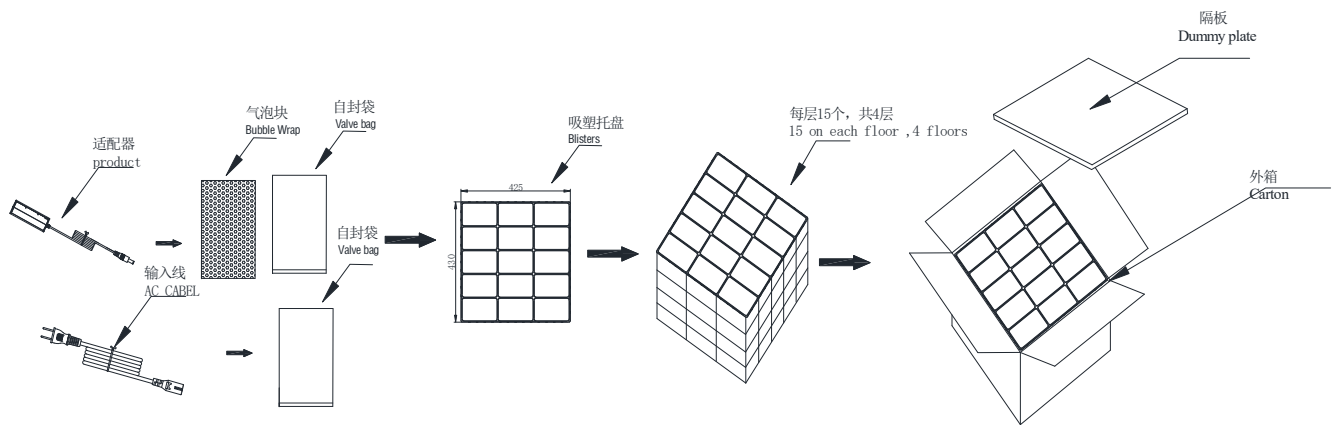

批准 Approval:	ZL	审核 Check:	ZL	制表 Execution:	BMD
--------------	----	-----------	----	---------------	-----

产品规格承认书 SPECIFICATION				文件编号 File No.	UME-EG-SP16092301/A1
品名 Product	开关电源 SPS	型号 Model	AD-C120P400	日期 Date	2024-5-14

11 材料清单 BOM

NO	ITEM	DESCRIPTION	SPECIFICATION	QTY	MANUFACTURER
1	PCB	PCB	UME-120500B-PCB	1	TXS/JT/MW/HG
2	RX1,RX2	Chip R	1MΩ±5% 1206	2	YAGEO/FengHua
3	R1,R13	Chip R	180Ω±5% 1206	2	YAGEO/FengHua
4	R2,R3	Chip R	510KΩ±5% 1206	2	YAGEO/FengHua
5	R4,R5	Dip R	1.5Ω±1% 1206	2	YAGEO/FengHua
6	R6,R7,R8	Dip R	2.0Ω±1% 1206	3	YAGEO/FengHua
7	R9	Dip R	150Ω±5% 1206	1	YAGEO/FengHua
8	R10,R28	Chip R	10KΩ±5% 0805	2	YAGEO/FengHua
9	R11	Chip R	6.8Ω±5% 0805	1	YAGEO/FengHua
10	R12,R14	Chip R	100KΩ±5% 1206	2	YAGEO/FengHua
11	R15	Chip R	27KΩ±5% 0805	1	YAGEO/FengHua
12	R16	Chip R	470Ω±5% 0805	1	YAGEO/FengHua
13	R17,R29,R20	Chip R	0Ω±5% 0805	3	YAGEO/FengHua
14	R18	Chip R	22Ω±5% 1206	1	YAGEO/FengHua
15	R19	Chip R	56Ω±5% 1206	1	YAGEO/FengHua
17	R21	Chip R	30KΩ±5% 0805	1	YAGEO/FengHua
18	R22,R23	Chip R	1KΩ±5% 0805	2	YAGEO/FengHua
19	R24	Chip R	20KΩ±1% 0805	1	YAGEO/FengHua
20	R25	Chip R	10KΩ±1% 0805	1	YAGEO/FengHua
21	R26	Chip C	10.5KΩ±1% 0805	1	YAGEO/FENG HUA
22	R27	Chip C	5.1KΩ±5% 0805	1	YAGEO/FENG HUA
23	R30	Chip C	47Ω±5% 0805	1	YAGEO/FENG HUA
24	C1,C8	Chip C	102 500V±10% 1206 X7R	2	YAGEO/FENG HUA
25		Chip C	102 630V±10% 1206 X7R		YAGEO/FENG HUA
26	C2	Chip C	471 50V 0805 COG	1	YAGEO/FENG HUA

批准 Approval:	ZL	审核 Check:	ZL	制表 Execution:	BMD
--------------	----	-----------	----	---------------	-----

产品规格承认书 SPECIFICATION				文件编号 File No.	UME-EG-SP16092301/A1
品名 Product	开关电源 SPS	型号 Model	AD-C120P400	日期 Date	2024-5-14

27	C3	Chip C	222 50V±10% 0805 X7R	1	YAGEO/FENG HUA
28	C4	Chip C	104 50V±10% 0805 X7R	1	YAGEO/FENG HUA
29	C6	Chip C	105 16V±10% 0805 X7R	1	YAGEO/FENG HUA
30	C7	Chip C	684 50V ±10% 0805 X7R	1	YAGEO/FENG HUA
31	U1	IC	OB2365EMP SOP-23	1	On Bright
32	U2	IC	CJ431±0.5% SOT-23	1	Changdian/UTC
33	U3	IC	OB2004 AMP SOT-23	1	On Bright
34	D1	Diode	M7 SMA	1	JF/MIC/PANJIT
36	D2	Diode	1N4148W 75V 0.15A SOD-123	1	JF/MIC/PANJIT
37	D3	Diode	F7 1A/1000V/SOD-123FL	1	JF/MIC/PANJIT
38	Q2	MOSFEET	KS8203CA 93A 75V TO-220	1	GUANYU
39	BD2	Rectifier Bridge	KBL406G 600V 4A P=5mm	1	XH/JF/PANJIT
40	LED	LED	3Ø LED Green	1	Hong Qi
41	FI	FUSE	*T3.15A/250V P=5mm	1	XC/SET/Little fuse
42	HS1	Heat Sink	70*20*2+33*30*2	1	Weiersi/LILIFA
43	HS2	Heat Sink	101*21*2	1	Weiersi/LILIFA
44	Q2	Insulation sheet	BUSHING-TO-220	1	GHT
45	Q2	Silicon Sheet	13*19*0.25 mm	1	GHT
46	Q1,Q2	Screw	Φ3*8	2	Yunzhan/jixin
47	Q1,Q2	Nut	Φ3mm	2	Yunzhan/jixin
48	CX1	X Cap	0.33uF 250V±20% P=15	1	STE
49	L1	Inductance	1.4uH MIN D4*15 Φ1.0	1	VS/NH
50	LF1	Inductance	0.6mH MIN 0.5 UEW+TLW	1	VS/NH
51	LF2	Inductance	20mH MIN 0.5 UEW+TLW	1	VS/NH
52	CN1	AC INLET	HD-805-3-P14	1	HUACONN
53		AC INLET	ST-A03-005KT10(N)2.0		BEJ
54	CY1,CY2	Y cap	Y2 472 250V±20% P=7.5	2	STE/HJ

批准 Approval:	ZL	审核 Check:	ZL	制表 Execution:	BMD
--------------	----	-----------	----	---------------	-----

产品规格承认书 SPECIFICATION				文件编号 File No.	UME-EG-SP16092301/A1
品名 Product	开关电源 SPS	型号 Model	AD-C120P400	日期 Date	2024-5-14

55	TR	TRANSFMOR	TRPQ2620-120500B	1	HXH/ ZY
56	PH1	Photo	EL-817MB DIP-4 P=10.2	1	Everlight
			BPC-817MB DIP-4 P=10.2		Bright Led
57	Q1	MOSFEET	10N65 650V 10A TO-220F	1	HF/FH/JF
58	EC1	E cap	82uF 400V±20% 105℃ Φ18*25mm(WH)	1	AISHI
59	EC2	E cap	10uF 50V±20% 105℃ Φ5*11mm(RR)	1	AISHI
60	EC3,EC4,EC5	E cap	1000uF 16V±20% 105℃8*16mm(RR)	3	AISHI
61	JP1	Jump line	Φ0.5mm	25	UME
62	HS2	Mike pull tape	150mm*73mm*0.05mm	1	YAHUA
63		Light Pipe	4.52*2.01*2.5+Φ6*Φ4.52 d=9.04mm	1	JinTonZhou
64		DC Cable	Φ2.1*5.5*9.5 2464 18AWG 1500mm BK	1	DPK/GC
65		AC Cable	<PS>E 2*0.75 mm ² VCTFK L=1800mm Black, Lead-free soldering	1	KLJ/JR
66		Case	UME 6005A BK	1	JLF/YGE
67		Case	UME 6005B BK	1	JLF/YGE
		Nameplate	NAP-120400A3	1	Jingxing
68		Bubble Wrap	195*115		
69		Valve bag	140*210*0.05mm	1	Xincheng
70		CARTON	470*380*255mm	0.01667	XinRuicheng/ FuXing
71		LINER	465*365*3mm	0.01667	XinRuicheng/ FuXing
72		Blisters	460*370*65mm	0.06667	Yuxiang
73		White glue	AP-688	1.2	JX
74		Solder Bar	Pb free	0.5	YUNNANXIYE
75		Solder wire	Pb free	0.1	YUNNANXIYE

批准 Approval:	ZL	审核 Check:	ZL	制表 Execution:	BMD
--------------	----	-----------	----	---------------	-----